

Product Index (cont'd)

Inductive Proximity Switches

Type Number	Diameter (mm)	Output Functions		Style		÷	Ⓢ	Page No.
		DC Types		Shielded	Unshielded			
		PNP	NPN					
PRX800	8			•	•	•		134
PRX801	8	•			•	•		134
PRX802	8	•		•		•		134
PRX803	8	•			•	•		134
PRX830	8		•	•		•		134
PRX831	8		•		•	•		134
PRX832	8		•	•		•		134
PRX833	8		•		•	•		134
PRX1200	12	•		•		•		135
PRX1201	12	•			•	•		135
PRX1202	12	•		•		•		135
PRX1203	12	•			•	•		135
PRX1220	12	•		•		•		135
PRX1230	12		•	•		•		135
PRX1231	12		•		•	•		135
PRX1232	12		•	•		•		135
PRX1233	12		•		•	•		135
PRX1260	12			•	•	•	•	135
PRX1261	12				•	•	•	135
PRX1800	18	•		•		•		136
PRX1801	18	•			•	•		136
PRX1802	18	•		•		•		136
PRX1803	18	•			•	•		136
PRX1820	18	•		•		•		136
PRX1830	18		•	•		•		136
PRX1831	18		•		•	•		136
PRX1832	18		•	•		•		136
PRX1833	18		•		•	•		136
PRX1860	18			•	•	•	•	136
PRX1861	18				•	•	•	136
PRX1862	18			•		•	•	136
PRX1863	18				•	•	•	136
PRX3000	30	•		•		•		138
PRX3001	30	•			•	•		138
PRX3002	30	•		•		•		138
PRX3003	30	•			•	•		138
PRX3030	30		•	•		•		138
PRX3062	30			•		•	•	138
PRX3063 DISC.	30				•	•	•	138
PRX3064	30			•		•	•	138
PRX3065	30				•	•	•	138

Inductive Proximity Switches

ECG Inductive Proximity Switches are precision, solid-state sensing devices that provide an attractive alternative to physically activated limit and control switches with their mechanical contacts, moving parts and attendant wear characteristics. ECG Proximity Switches are fully sealed against most hostile industrial environments. They are impervious to oils, organic cleaners, steam, water and dust as well as being immune to vibration. Usual positioning and operational constraints are virtually eliminated, while life span remains unaffected by problems related to mechanical wear.

Proximity switches will operate electromechanical devices such as relays, contactors, solenoids, counters and valves without additional interface components. Also, DC types provide an output compatible with solid state loads, including programmable controllers. Proximity switches offer reliable and long-lived operation in applications as diverse as machine tools, conveyors, automated warehouses, wood working machines, robotics, farm machinery, packaging equipment, production lines and general automation. Philips ECG offers a broad range of types to meet the variety of users' needs.

Operating Principle

An inductive proximity switch has three functional sections or stages, as shown in Figure 1. They are: a radio frequency (RF) oscillator circuit that incorporates a coil with a ferrite core, a Schmidt trigger circuit, and a solid state output switching device (transistor in DC types, thyristor in AC types).

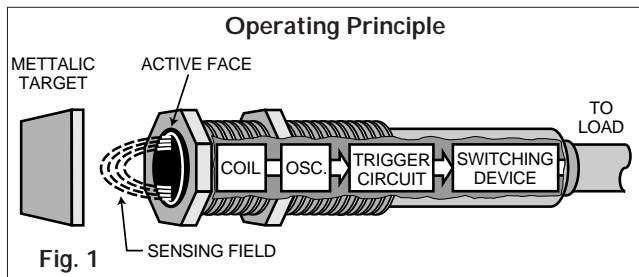

The oscillator circuit generates an electromagnetic field which is radiated from the active face of the switch. A metal object (target) introduced into this sensing field absorbs energy from the oscillator which, in turn, reduces the amplitude of oscillation. The trigger circuit detects the reduction and in response produces a signal that closes the output stage switching device. When the target leaves the sensing field the oscillator regenerates and the switch resets.

ECG Inductive Proximity Switches are responsive to all electrically conductive materials. They cannot, however, distinguish between different materials.

Sensing Characteristics

The target can approach the switch in either of two ways, as illustrated in Figure 2. In the **Axial** plane the target approaches "head-on" along the major axis of the switch, perpendicular to the active face. In the **Radial** plane the target approaches and/or "slides by" the switch along a path parallel to the active face.

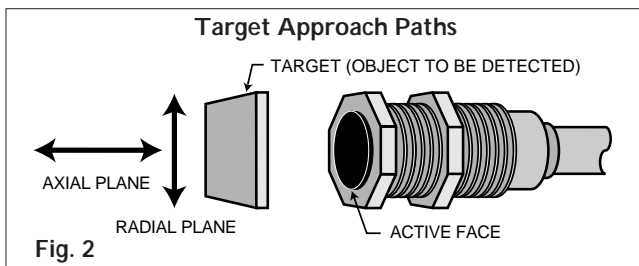

In practice, the target should not come in contact with the switch. A minimum separation between the target and active face is prerequisite and should be assured at all times to prevent mechanical wear.

Sensing Distance (S_n)

This is the distance at which a metallic target approaching the active face in the Axial plane ("head-on") activates the switch, Figure 3.

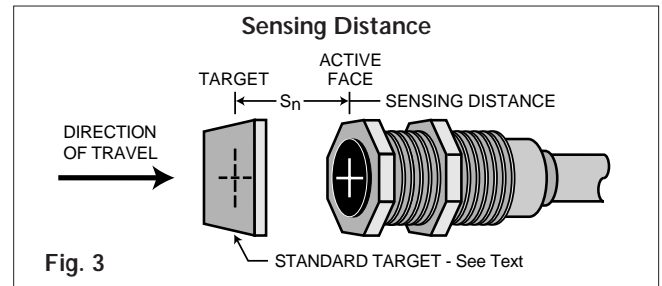

Sensing Distance is affected by target size, shape and composition. Therefore, catalog values are given for a Standard Target. This is a square of mild steel (low carbon) 1.0 mm thick with side measurements equal to the diameter of the switch or three times the sensing distance, whichever is greater.

Targets which are smaller than the Standard Target, not flat or made of non-ferrous metal will reduce the Sensing Distance. It should be noted that if the target is larger than the Standard Target the Sensing Distance will not be increased.

Correction Factors - Non-Ferrous Metals: ECG proximity switches will detect all metals, but have a greater sensitivity to ferrous metals. If non-ferrous metals are to be detected, a shorter Sensing Distance must be used. Listed below are approximate correction factors for certain non-ferrous metals.

Material	Factor
Chrom-Nickel	0.9 x Sensing Distance
Brass	0.5 x Sensing Distance
Aluminum	0.4 x Sensing Distance
Copper	0.4 x Sensing Distance

Sensing Distance vs. Switch Size: Sensing Distance is also directly related to switch diameter. The greater the diameter, the greater the Sensing Distance. Philips ECG offers a broad range of switch diameters to provide just the Sensing Distance required:

Switch Diameter in mm	Sensing Distance (S_n) in mm	
	Shielded	Unshielded
8 (Series 800)	1.5	2.5
12 (Series 1200)	2.0	4.0
18 (Series 1800)	5.0	8.0
30 (Series 3000)	10.0	15.0

Axial and Radial Sensing Characteristics

Sensing characteristics in the **Axial** (head-on) and **Radial** (slide-by) actuation modes are illustrated in Figure 4.

Axial Mode: In this mode or plane note that there is a difference in the distance at which the switch activates (closes) as the target approaches and the distance at which the switch deactivates (opens) as the target recedes. This characteristic is referred to as **Switching Hysteresis** and is typically 15 percent of the Sensing Distance (S_n). Hysteresis provides compensation for target vibration and minor surface irregularities that might otherwise cause false signals.

Radial Mode: In this mode, the distance between the active face of the switch and the target should not exceed 81 per-cent of the specified Sensing Distance (S_n) of the particular switch. Operation within this zone is assured and is independent of variations, within ratings, of temperature and voltage.

ECG® Relays and Accessories

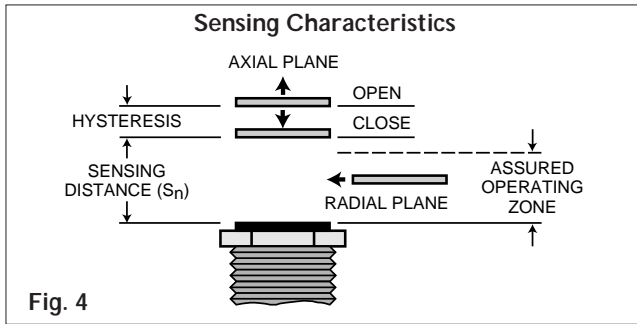

Switching Frequency

Switching Frequency represents the maximum number of targets per second that a proximity switch is capable of detecting. As shown in Figure 5, it is specified for the **Radial** actuation mode (slide-by) at a sensing distance of $0.5 S_n$ with a Standard Target and a pulse-to-pause ratio of 1:2.

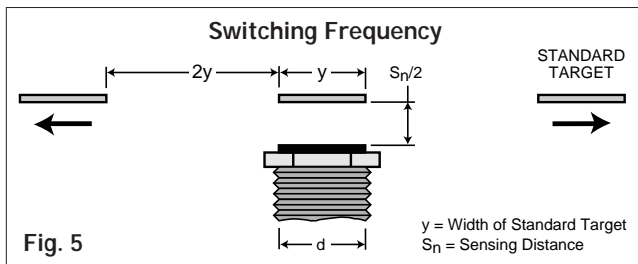

Shielded and Unshielded Styles

ECG proximity switches are available in two styles: Shielded and Unshielded. The distinguishing characteristics are illustrated in Figure 6.

Shielded (Flush Mounting): This style of switch has the active face essentially even with the threaded end of the switch housing, Figure 6A. The shielded design can be flush mounted in metal with no change in performance characteristics.

Unshielded (Non-Flush Mounting): As shown in Figure 6B, the active face of the unshielded switch extends well beyond the threaded end of the housing, thus exposing a larger area from which the electromagnetic sensing field can radiate. This style is somewhat side sensitive and, consequently, can not be flush mounted in metal. A metal-free zone about the sensing face is required as described in the Section **Mounting and Installation**.

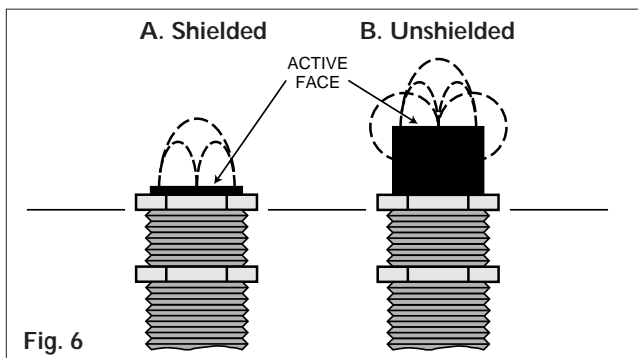

Switch Configurations

AC Types

AC proximity switches are 2-terminal, normally open devices which are powered by line voltage. No secondary (external) power source is needed. This feature permits them to be directly substituted for electromechanical limit switches without

additional wiring. They can operate relays, solenoids, contactors, etc., at switching rates up to 15 operations per second, depending on the switch type.

Both shielded and unshielded styles are offered by Philips ECG in 12, 18 and 30 mm sizes with sensing distance of 2 to 15 mm, and operating voltage ranges of 35 to 250 VAC and 90 to 250 VAC. Maximum load current of all types is 250 mA.

AC switches are available both with and without Ground, Figure 7. Operation is identical. When not sensing a target, the output is open (non-conductive). When a metal target enters the sensing field the output closes (becomes conductive) and energizes the load.

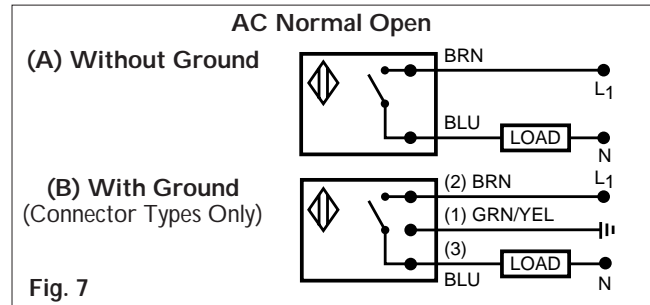

When the switch is open, a small leakage current (1.5 mA max.) flows through the load. When closed, there is a voltage drop across the output of up to 8.5 volts. These characteristics must be taken into consideration, especially when several proximity switches are to be connected in series or parallel (see section entitled **Series and Parallel Operation**). Operation in combination with switches that have mechanical contacts is also feasible.

AC proximity switches are not protected against voltage or current overload. Accidental short circuit of the load in the closed (conductive) state will **destroy** the switch. Also, power should never be applied to the switch in the absence of a load. Protection is provided against RFI (radio frequency interference).

DC Types

DC proximity switches offer the advantages of high switching frequency (up to 1000 Hz in the 8mm size), low voltage drop and minimal leakage current. In addition, their output is compatible with solid state loads, including programmable controllers. They can also be used to directly drive electro-mechanical devices, such as relays, counters, etc. Operation in combination with mechanical contacts is also practical. DC proximity switches do require a separate power supply; however, regulation is not generally necessary.

Both shielded and unshielded switch styles are supplied by Philips ECG in 8, 12, 18 and 30 mm sizes with sensing distances of 1.5 to 15 mm, an operating voltage range of 10-30 VDC and a maximum load current capability of 200 mA.

Switching configurations include PNP Normal Open, NPN Normal Open, and PNP Complementary.

PNP Normal Open (Current Sourcing) - Figure 8: The load is tied to the **Negative** (common) side of the power supply. The output transistor switches the positive side of the supply to the load. The PNP output function is also known as Current Sourcing since the current for the load is "sourced" by the proximity switch.

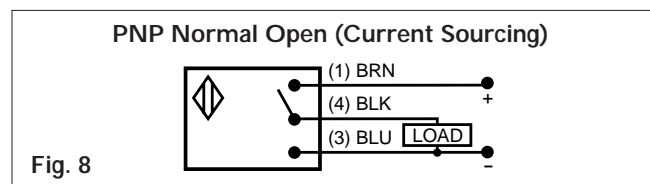

ECG® Relays and Accessories

NPN Normal Open (Current Sinking) - Figure 9: The load is tied to the **Positive** side of the power supply. The output transistor switches the negative (common) supply line to the load. The NPN output function is also known as Current Sinking since the current passes through the load first and “sinks” through the switch.

When not sensing a target, the output of both PNP and NPN models is open (non-conductive). It closes (becomes conductive) when a target is sensed.

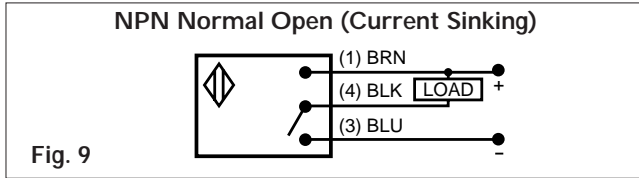

Complementary Normal Open/Normal Closed - Figure 10: DC proximity switches of the complementary type have two outputs: one normally open and another which is normally closed. The two outputs change state simultaneously when a target is detected. Both output transistors are PNP (current sourcing).

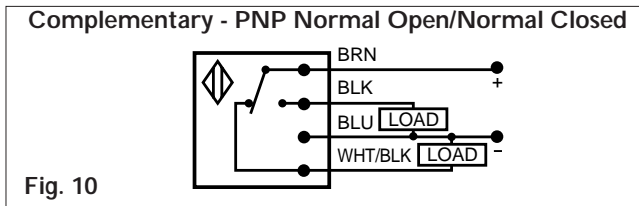

Most electromechanical loads (relays, counters, etc.) will accommodate either PNP or NPN types, providing they are correctly wired. The proper output function **must** be chosen for solid state loads and programmable controllers. For series and parallel operation, and application in combination with mechanical contacts, see section entitled **Series and Parallel Operation**.

Power Supply: Regulation of supply voltage is not required providing rated switch Operating Voltage is maintained within the limits specified. Supply Voltage Ripple **must not** exceed 15% of the Operating Voltage.

Protective Features: DC proximity switches are protected against accidental polarity reversal, as well as short circuit of the load. They are also immune to RFI (radio frequency interference).

Series and Parallel Operation

Series Connection

AC Switches: Series operation of AC proximity switches is shown in Figure 11. Care must be taken to assure that there is sufficient voltage to the load for it to operate properly. In the closed (conductive) state there is a drop in voltage (loss) across each switch of 8-9 volts at maximum rated current. As the number of switches in series is increased, the loss becomes appreciable and can be enough to prevent the load from operating as it should. It is recommended that no more than four switches be wired in series at 240 VAC and no more than two switches at 120VAC. Series operation below 90 VAC is not

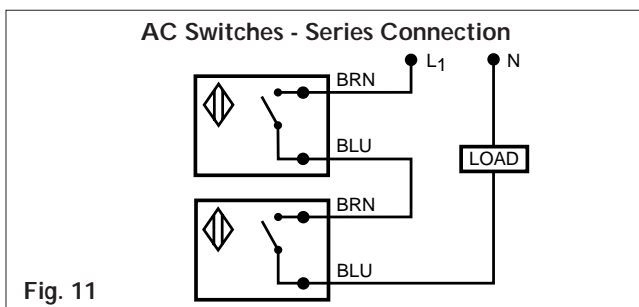

recommended. A combination of mechanical contact switches and proximity switches is possible.

DC Switches: Series connection of DC proximity switches is shown in Figures 12 and 13 for normally open types with PNP (sourcing) and NPN (sinking) output functions.

A voltage drop of up to 2.5 volts occurs with each switch connected in series. Therefore, the voltage available to the load will be reduced by this amount by each switch in the string. Each proximity switch must be capable of supplying the deactivated (“standby”) current of the other switches, as well as the external load current. Proximity switches can be applied in combination with mechanical contact switches.

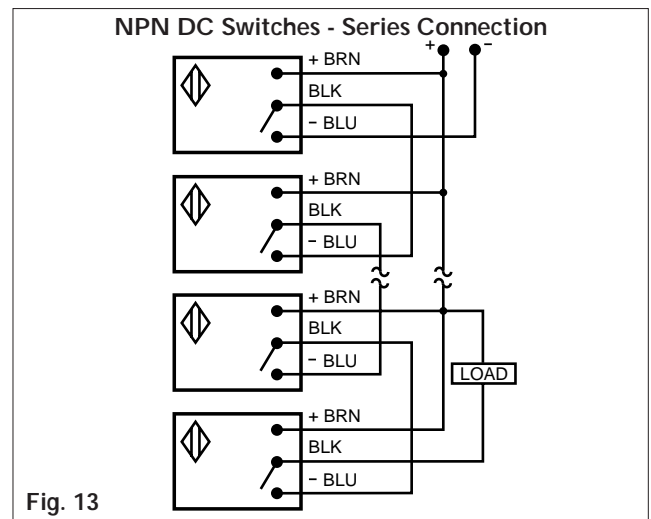
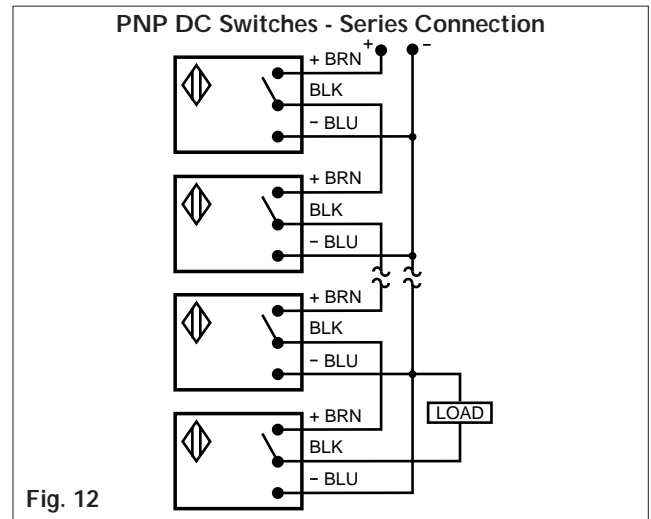

Parallel Connection

AC Switches: Parallel connection of AC proximity switches is illustrated in Figure 14. The number of switches that can be paralleled is a function of switch leakage current (up to 1.5 mA max. each) and the load impedance. The sum of the leakage currents must be less than the dropout current of the load.

It must be noted that when any of the switches connected in parallel is closed, the remaining switches will then function in an “exclusive OR” mode. That is, if another switch senses that it should close after the first one does, the second switch will be prevented from doing so until 100 ms after the first switch opens.

When connecting AC proximity switches in parallel with mechanical contacts, potentially damaging transient voltage spikes may be produced when interrupting inductive loads, e.g., contactors, relays, solenoids. To prevent damage to the switch from these voltage spikes, surge suppressors should be used at the source of the spikes.

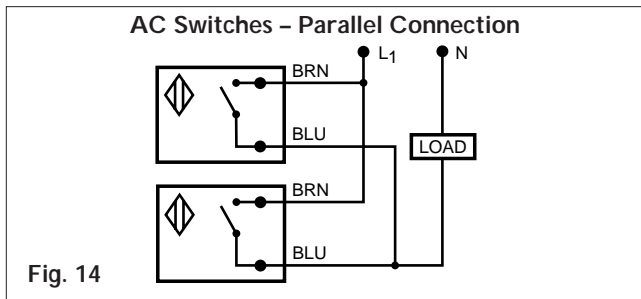

Fig. 14

DC Switches: Proximity switches can be operated in parallel to give an “OR” function. Circuits are shown in Figures 15 and 16 for normally open switches with PNP (sourcing) and NPN (sinking) output functions.

The isolation diodes shown are essential with proximity switches that have built-in LED status indicators. Otherwise, all the LEDs will light when one switch closes. Also, without the diodes, each switch must be capable of supplying the deactivated current (“standby current”) of all the switches, as well as the current required by the external load.

When connecting DC proximity switches in parallel with mechanical contacts, potentially damaging transient voltage spikes may be produced when interrupting inductive loads. To protect against damage from these voltage spikes and possible false operation, surge suppressors should be used at the source of the spikes.

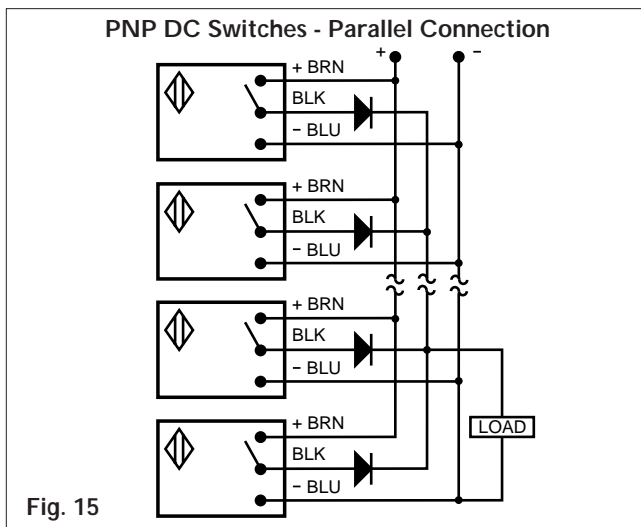

Fig. 15

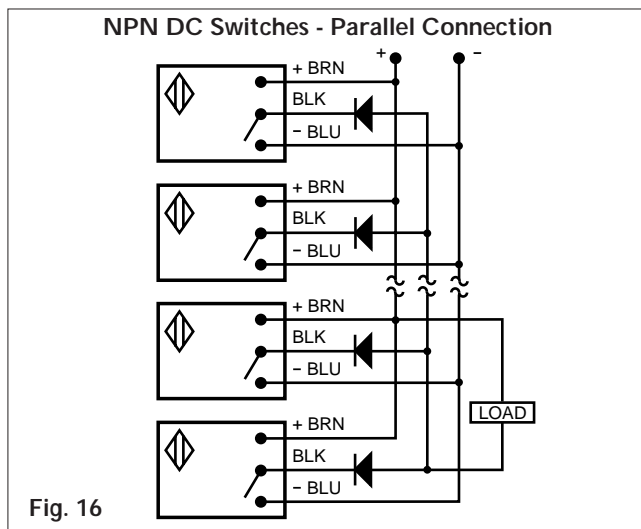

Fig. 16

Mounting and Installation

Shielded and Unshielded

Shielded (Flush Mounting): Shielded proximity switches can be embedded in metal up to the plane of its active face (flush mounted) without operational limitations, Figure 17A.

Unshielded (Non-Flush Mounting): The unshielded style of proximity switch requires a metal-free zone around the active face, as illustrated in Figure 17B. This area must be kept free of conductive metals or other materials that possess magnetic properties. The depth should measure no less than the diameter of the switch housing. The diameter of the metal-free zone should be at least three times that of the switch housing.

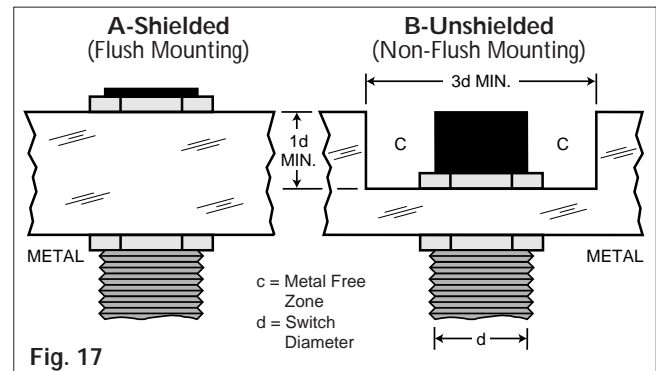

Fig. 17

Side-By-Side

Proximity switches can be mounted side-by-side, Figure 18. However, they must be spaced far enough apart to prevent the electromagnetic sensing field radiated by one switch from affecting operation of the other switch. Shielded switches should be spaced on centers a minimum distance of twice the diameter of the switch housing, Figure 18A. Unshielded switches should be spaced a minimum of three times the diameter of the switch housing, Figure 18B.

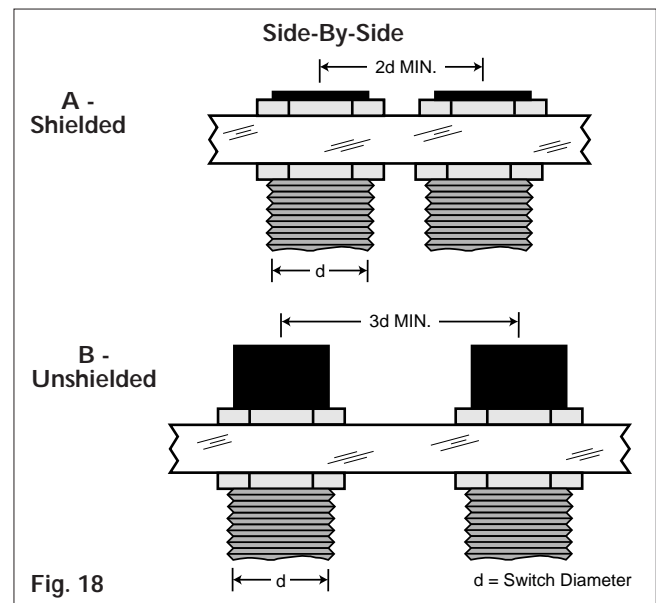
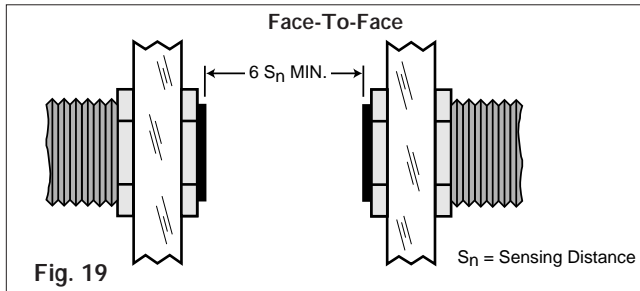

Fig. 18

Face-To-Face

Proximity switches can also be mounted facing one another, Figure 19. When so positioned, a minimum distance of six times the rated sensing distance (S_n) must separate their active faces to preclude possible interaction between the switches.

ECG® Relays and Accessories



Facing Metal

Mounting directly opposite a metal surface is another viable option, Figure 20. As shown, the distance between the active face of the proximity switch and the opposing metal surface should be a minimum of three times the rated sensing distance (S_n) of the particular switch.

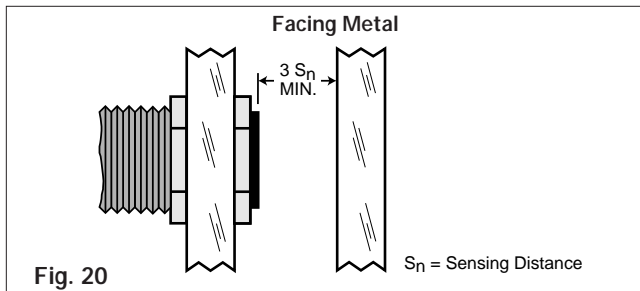

Installation - Torquing

It is recommended that ECG proximity switches be clamped in position using two nuts (and lock washers when specified), one on each side of the mounting surface. If these nuts are overtightened, it is possible to damage the switch housing. Therefore, care should be taken not to exceed the torque values given in the following table:

Switch Diameter	Maximum Torque
8mm (Series 800)	
Connector Types	8 ft. lbs.
Cable Types	4 ft. lbs.
12mm (Series 1200)	
DC Types	15 ft. lbs.
AC Types	8 ft. lbs.
18mm (Series 1800)	35 ft. lbs.
30mm (Series 3000)	44 ft. lbs.

Brackets and Adapters

To simplify installation, universal mounting brackets and microswitch adapter brackets are available in most switch sizes. See Accessories section, Page 165.

CAUTION: Especially high transient voltages can be introduced by cables which carry high currents for motors, solenoids, clutches, etc. These could cause damage to the proximity switch or activate its short circuit protection. This can be minimized by separating switch wiring from such cables.

Terms and Definitions

Active Face: The surface of the proximity switch from which the sensing field is radiated. Also known as "sensing surface".

Complementary Output: A DC operated proximity switch with both Normally Open (N.O.) and Normally Closed (N.C.) outputs that change state simultaneously when a target is detected.

Current Consumption - Activated: Current drawn by a DC proximity switch with no load when its output is CLOSED (conductive state). Value given is at maximum rated Operating Voltage. Also known as "damped" current consumption and "standby" current.

Current Consumption - Deactivated: Current drawn by a DC proximity switch with no load when its output is OPEN (non-

conductive state). Value given is at maximum rated Operating Voltage. Also known as "undamped" current consumption.

Eddy Currents: Small circulating currents induced in the surface of a metallic target by the sensing field (flux) from an inductive proximity switch.

Excitation Delay: The length of time required for a proximity switch to become operational upon the application of power.

Inrush Current: The maximum Load Current that an AC proximity switch can withstand for a short duration (20 mS) when the switch is CLOSED (conductive state).

Leakage Current: The amount of current that flows through an AC proximity switch when it is OPEN (non-conductive state).

Load Current - Maximum: The highest value of current at which AC and DC proximity switches can be continuously operated. Exceeding this rating may cause permanent damage to the switch.

Load Current - Minimum: The amount of current that the load of an AC proximity switch must draw when CLOSED (conductive state) in order for the switch to operate properly, i.e., reset when deactivated.

N/C: No connection.

N.C. (Normal Closed): A proximity switch with a normally closed output that OPENS (becomes non-conductive) when a target is detected. Also known as a "break" switching configuration or function.

N.O. (Normal Open): A proximity switch with a normally open output that CLOSSES (becomes conductive) when a target is detected. Also known as a "make" switching configuration or function.

NPN (Current Sinking): A negative switching output in which the load current passes through the load first, then "sinks" through the proximity switch.

Operating Temperature: The range in ambient temperature over which the proximity switch can be operated. Operation outside the given limits will result in instability and possible permanent damage to the switch.

Operating Voltage: The range of voltage that can be used to operate a proximity switch. Also called "supply" voltage.

Output Resistance: Value of resistance internal to a DC proximity switch that appears in parallel with the external load resistance. When the output stage of the switch is OPEN (non-conductive) it is the resistance "seen" by the load.

Parallel Capacitance to Load: Maximum permissible value of capacitance in parallel with the load of a DC proximity switch.

PNP (Current Sourcing): A positive switching transistor output in which the current for the load "sources" through the proximity switch.

Repeatability: Ability of a proximity switch to repeatedly detect a target at the same distance from the Active Face. Expressed as a percentage of Sensing Distance (S_n).

Sensing Distance (S_n): The nominal distance ($\pm 10\%$) at which a proximity switch will detect a target approaching in a plane perpendicular to the Active Face. Specified at an Operating Temperature of 25°C with a Standard Target. Also known as "operating point".

Shielded: A style of proximity switch that has its Active Face even with the end of the switch housing and can be flush mounted in metal.

Standard Target: A reference used for calibration and initial setup. Consists of a square of low-carbon steel 1.0 mm thick with side measurements equal to the diameter of the switch or three times the specified Sensing Distance (S_n), whichever is greater.

Supply Voltage Ripple: The maximum permissible peak-to-peak AC voltage component superimposed on the average value of DC voltage, expressed in percent.

Switching Frequency: The maximum number of targets (objects) per second that the proximity switch is capable of detecting. Catalog value is based on a Standard Target at a distance of 0.5 S_n and a pulse-to-pause ratio of 1:2.

Switching Hysteresis: The difference between switching points of an approaching and a receding target in the axial plane. Expressed as a percentage of the specified Sensing Distance (S_n). Also called "differential".

Unshielded: A style of proximity switch that has its active face extended beyond the end of the switch housing. Unshielded switches are somewhat side-sensitive and cannot be flush mounted in metal.

Voltage Drop: The voltage "lost" across the output stage of a proximity switch when the switch is CLOSED (conductive state). Catalog value is at maximum rated Operating Voltage and Load Current.

Series PRX800

8 mm Diameter Inductive Proximity Switches



- Metal Housing
- Shielded & Unshielded
- Micro Connector /Cable Types
- RFI Protected
- Short Circuit Protected
- Reverse Polarity Protected
- LED Indicator

Ratings and Specifications

ECG Type	Output Function		Style		Termination	Sensing Distance S_n (mm)	Operating Voltage (V)	Switching Freq. Max. (Hz)	Body Length (mm)	Fig. No.	Wiring Diag.	
	DC Types		AC Types	Shielded Flush Mounting								Unshielded Non-Flush Mounting
	PNP (Source)	NPN (Sink)										
PRX*800	N.O.			■	Cable	1.5	10-30 DC	1000	45	P3	A	
PRX801	N.O.			■	Cable	2.5	10-30 DC	1000	45	P4	A	
PRX802	N.O.			■	Connector	1.5	10-30 DC	1000	70	P1	A	
PRX803	N.O.			■	Connector	2.5	10-30 DC	1000	72.5	P2	A	
PRX830		N.O.		■	Cable	1.5	10-30 DC	1000	45	P3	D	
PRX831		N.O.		■	Cable	2.5	10-30 DC	1000	45	P4	D	
PRX832		N.O.		■	Connector	1.5	10-30 DC	1000	70	P1	D	
PRX833		N.O.		■	Connector	2.5	10-30 DC	1000	72.5	P2	D	

* PRX is a trademark of North American Philips Corporation

DC Types (PNP & NPN)

- Load Current ▲200 mA Max.
 Current Consumption
 Activated25 mA Max.
 Deactivated12 mA Max.
 Voltage Drop2.5 V Max.
 Supply Voltage Ripple15% Max.
 Output Resistance2.2 K Ω + Diode & LED
 Parallel Cap. to Load..0.5 μ F Max. @ 24 VDC

General

- Operating Temp.....-25°C to +70°C
 Repeatability......5% Of S_n
 Switching Hysteresis.....15% Of S_n
 Housing.....Nickel Plated Brass
 Diameter8mm
 Thread.....M8 x 1

Nut Tightening Torque

- Cable Types.....4 Ft. Lbs. Max.
 Connector Types.....8 Ft. Lbs. Max.
 Cable Length/Wire Size3 M/22 AWG
 NEMA Ratings.....4, 4X, 6, 11, 12, 13, 18

▲ Rated At Max Operating Voltage and Temperature.

Accessories

Part No.	Description
PRX9000	DC Connector/Cable, Straight
PRX9001	DC Connector/Cable, Rt Angle
PRX9108	Mounting Bracket

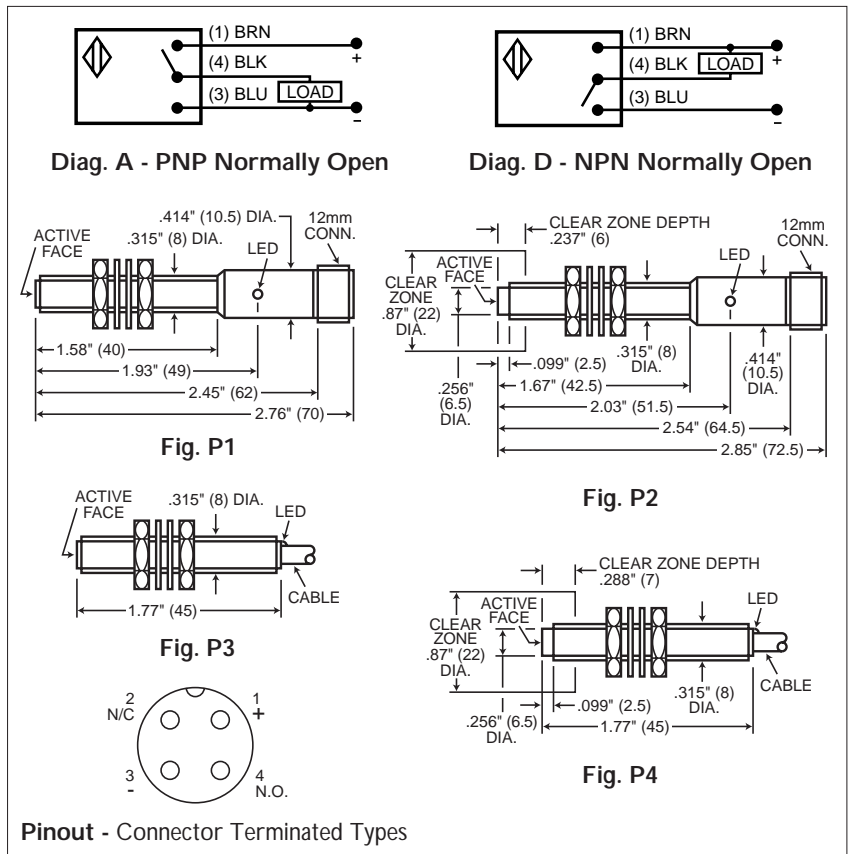

Series PRX1200



12 mm Diameter Inductive Proximity Switches

- Metal Housing
- Shielded & Unshielded
- Micro Connector /Cable Types
- RFI Protected
- Short Circuit Protected (DC Types)
- Reverse Polarity Protected
- LED Indicator

Ratings and Specifications

ECG Type	Output Function		Style		Termination	Sensing Distance S _n (mm)	Operating Voltage (V)	Switching Freq. Max. (Hz)	Body Length (mm)	Fig. No.	Wiring Diag.
	DC Types		Shielded Flush Mounting	Unshielded Non-Flush Mounting							
	PNP (Source)	NPN (Sink)									
PRX*1200	N.O.		■		Cable	2	10-30 DC	800	60	P22	A
PRX1201	N.O.			■	Cable	4	10-30 DC	400	60	P25	A
PRX1202	N.O.		■		Connector	2	10-30 DC	800	70	P20	A
PRX1203	N.O.			■	Connector	4	10-30 DC	400	70	P21	A
PRX1220	Compl.†		■		Cable	2	10-30 DC	800	60	P22	C
PRX1230		N.O.	■		Cable	2	10-30 DC	800	60	P22	D
PRX1231		N.O.		■	Cable	4	10-30 DC	400	60	P25	D
PRX1232		N.O.	■		Connector	2	10-30 DC	800	70	P20	D
PRX1233		N.O.		■	Connector	4	10-30 DC	400	70	P21	D
PRX1260			■		Cable	2	35-250 AC	10	60	P22	G
PRX1261				■	Cable	4	35-250 AC	10	60	P25	G

* PRX is a trademark of North American Philips Corporation
 † Complementary N. O. and N. C. Outputs

DC Types (PNP & NPN)

Load Current ▲200 mA Max.
 Current Consumption
 Activated25 mA Max.
 Deactivated12 mA Max.
 Voltage Drop2.5 V Max.
 Supply Voltage Ripple15% Max.
 Output Resistance2.2 KΩ + Diode & LED
 Parallel Cap. to Load1 μF Max. @ 24 VDC

AC Types

Load Current ▲5 Min. to 150 Max. mA
 Inrush Current1 A for 20 ms Max.
 Voltage Drop8.5 V Max.
 Supply Voltage Frequency45-65 Hz
 Leakage Current1.5 mA Max.
 Excitation Delay100 ms Max.

General

Operating Temp-25°C to +70°C
 Repeatability5% Of S_n
 Switching Hysteresis15% Of S_n
 HousingNickel Plated Brass
 Diameter12mm
 ThreadM12 x 1

Nut Tightening Torque

Cable Types15 Ft. Lbs. Max.
 Connector Types8 Ft. Lbs. Max.

Cable Length/Wire Size3 M/22 AWG
 NEMA Ratings4, 4X, 6, 11, 12, 13, 18

▲ Rated At Max Operating Voltage and Temperature.

Accessories

Part No.	Description
PRX9000	DC Connector/Cable, Straight
PRX9001	DC Connector/Cable, Rt Angle
PRX9112	Mounting Bracket
PRX9212	Microswitch Adapter

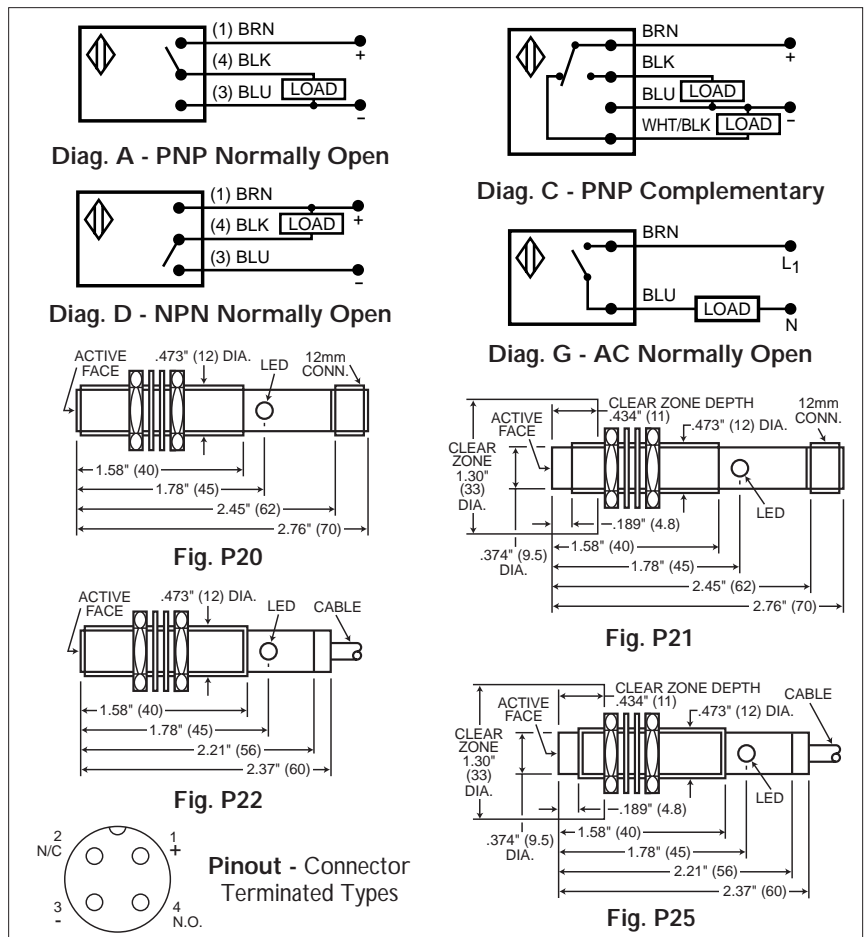

Series PRX1800



18 mm Diameter Inductive Proximity Switches

- Metal Housing
- Shielded & Unshielded
- Micro Connector /Cable Types
- RFI Protected
- Short Circuit Protected (DC Types)
- Reverse Polarity Protected
- LED Indicator

Ratings and Specifications

ECG Type	Output Function			Style		Termination	Sensing Distance S_n (mm)	Operating Voltage (V)	Switching Freq. Max. (Hz)	Body Length (mm)	Fig. No.	Wiring Diag.
	DC Types		AC Types	Shielded Flush Mounting	Unshielded Non-Flush Mounting							
	PNP (Source)	NPN (Sink)										
PRX*1800	N.O.			■		Cable	5	10-30 DC	500	76	P40	A
PRX1801	N.O.			■	■	Cable	8	10-30 DC	200	76	P41	A
PRX1802	N.O.			■		Connector	5	10-30 DC	500	83	P44	A
PRX1803	N.O.			■	■	Connector	8	10-30 DC	200	83	P45	A
PRX1820	Compl. †			■		Cable	5	10-30 DC	500	76	P40	C
PRX1830		N.O.		■		Cable	5	10-30 DC	500	76	P40	D
PRX1831		N.O.		■	■	Cable	8	10-30 DC	200	76	P41	D
PRX1832		N.O.		■		Connector	5	10-30 DC	500	83	P44	D
PRX1833		N.O.		■	■	Connector	8	10-30 DC	200	83	P45	D
PRX1860			N. O.	■		Cable	5	35-250 AC	10	88	P40	G
PRX1861			N. O.	■	■	Cable	8	35-250 AC	10	88	P41	G
PRX1862			N. O.	■		Connector	5	35-250 AC	10	83	P44	H
PRX1863			N. O.	■	■	Connector	8	35-250 AC	10	83	P45	H

* PRX is a trademark of North American Philips Corporation
 † Complementary N.O. and N.C. Outputs

DC Types (PNP & NPN)

Load Current ▲200 mA Max.
 Current Consumption
 Activated25 mA Max.
 Deactivated12 mA Max.
 Voltage Drop2.5 V Max.
 Supply Voltage Ripple15% Max.
 Output Resistance.....2.2 K Ω + Diode & LED
 Parallel Cap. to Load....1 μ F Max. @ 24 VDC

AC Types

Load Current ▲5 Min. to 250 Max. mA
 Inrush Current2 A for 20 ms Max.
 Voltage Drop8.5 V Max.
 Supply Voltage Frequency45-65 Hz
 Leakage Current1.5 mA Max.
 Excitation Delay100 ms Max.

General

Operating Temp.....-25°C to +70°C
 Repeatability5% Of S_n
 Switching Hysteresis.....15% Of S_n
 HousingNickel Plated Brass
 Diameter18mm
 ThreadM18 x 1
 Nut Tightening Torque.....35 Ft. Lbs. Max.
 Cable Length/Wire Size3 M/22 AWG
 NEMA Ratings4, 4X, 6, 11, 12, 13, 18

▲ Rated At Max Operating Voltage and Temperature.

Note: Series PRX1800 continued on next page

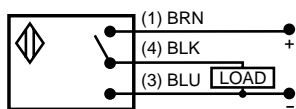

Diag. A - PNP Normally Open

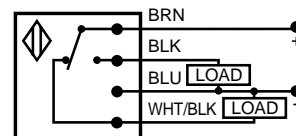

Diag. C - PNP Complementary

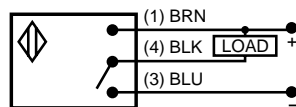

Diag. D - NPN Normally Open

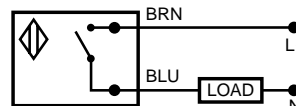

Diag. G - AC Normally Open

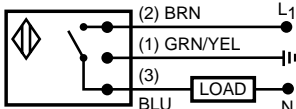

Diag. H - AC Normally Open

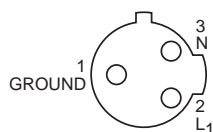

AC

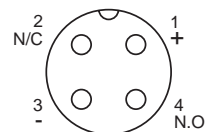

DC

Pinout - Connector Terminated Types

ECG® Relays and Accessories

Series PRX1800 (cont'd)

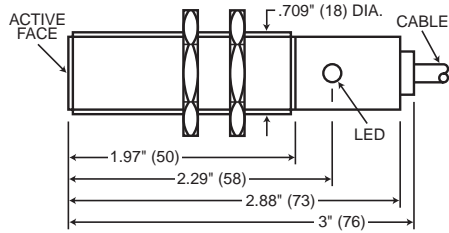

Fig. P40

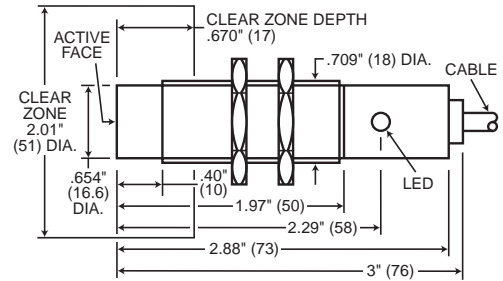

Fig. P41

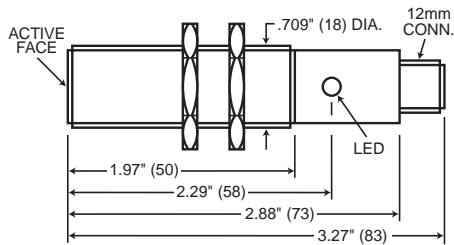

Fig. P44

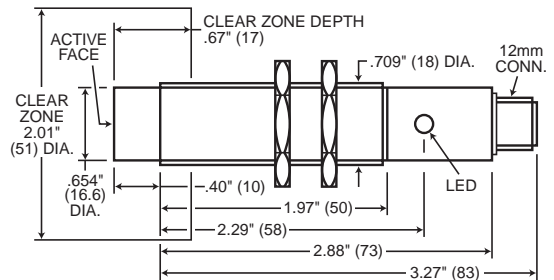

Fig. P45

Accessories

Part No.	Description
PRX9000	DC Connector/Cable, Straight
PRX9001	DC Connector/Cable, Rt Angle
PRX9002	AC Connector/Cable, Straight
PRX9003	AC Connector/Cable, Rt Angle
PRX9118	Mounting Bracket
PRX9218	Microswitch Adapter

Series PRX3000



30 mm Diameter Inductive Proximity Switches

- Metal Housing
- Shielded & Unshielded
- Micro Connector / Cable Types
- RFI Protected
- Short Circuit Protected (DC Types)
- Reverse Polarity Protected
- LED Indicator

Ratings and Specifications

ECG Type	Output Function		Style		Termination	Sensing Distance S _n (mm)	Operating Voltage (V)	Switching Freq. Max. (Hz)	Body Length (mm)	Fig. No.	Wiring Diag.
	DC Types		Shielded Flush Mounting	Unshielded Non-Flush Mounting							
	PNP (Source)	NPN (Sink)									
PRX*3000	N.O.		■		Cable	10	10-30 DC	300	76.5	P60	A
PRX3001	N.O.			■	Cable	15	10-30 DC	100	76.5	P61	A
PRX3002	N.O.		■		Connector	10	10-30 DC	300	88	P62	A
PRX3003	N.O.			■	Connector	15	10-30 DC	100	88	P63	A
PRX3030		N.O.	■		Cable	10	10-30 DC	300	76.5	P60	D
PRX3062			■		Connector	10	35-250 AC	10	83	P66	H
•PRX3063				■	Connector	15	35-250 AC	10	83	P67	H
PRX3064			■		Cable	10	90-250 AC	15	55	P64	G
PRX3065				■	Cable	15	90-250 AC	15	55	P65	G

* PRX is a trademark of North American Philips Corporation

• Discontinued

DC Types (PNP & NPN)

Load Current ▲.....200 mA Max.

Current Consumption

Activated.....25 mA Max.

Deactivated.....12 mA Max.

Voltage Drop.....2.5 V Max.

Supply Voltage Ripple.....15% Max.

Output Resistance.....2.2 KΩ + Diode & LED

Parallel Cap. to Load.....1 μF Max. @ 24 VDC

AC Types

Load Current ▲.....5 Min. to 250 Max. mA

Inrush Current.....2 A for 20 ms Max.

Voltage Drop.....8.5 V Max.

Supply Voltage Frequency.....45-65 Hz

Leakage Current.....1.5 mA Max.

Excitation Delay.....100 ms Max.

General

Operating Temp.....-25°C to +70°C

Repeatability.....5% Of S_n

Switching Hysteresis.....15% Of S_n

Housing.....Nickel Plated Brass

Diameter.....30mm

Thread.....M30 x 1.5

Nut Tightening Torque.....44 Ft. Lbs. Max.

Cable Length/Wire Size.....3 M/22 AWG

NEMA Ratings.....4, 4X, 6, 11, 12, 13, 18

▲ Rated At Max Operating Voltage and Temperature.

Accessories

Part No.	Description
PRX9000	DC Connector/Cable, Straight
PRX9001	DC Connector/Cable, Rt Angle
PRX9002	AC Connector/Cable, Straight
PRX9003	AC Connector/Cable, Rt Angle
PRX9130	Mounting Bracket

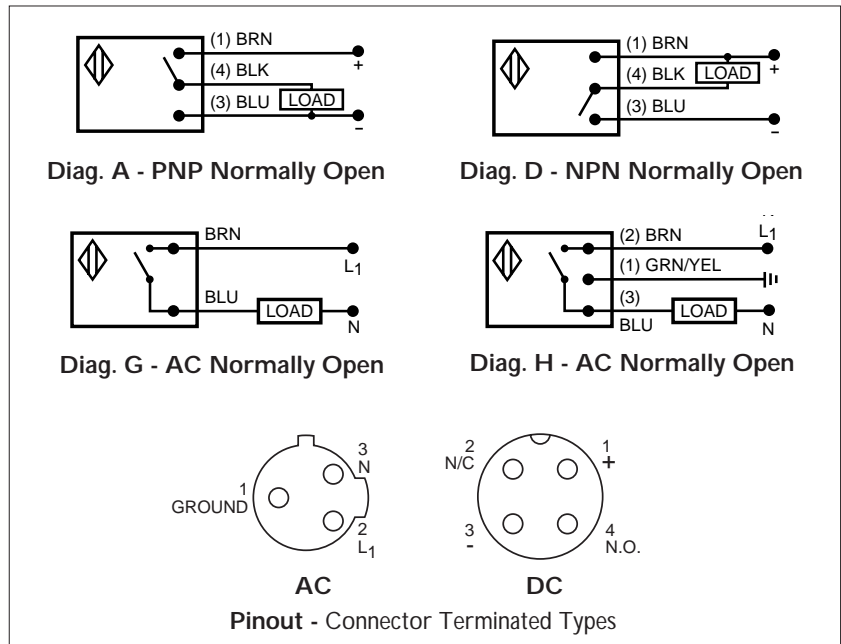

Note: Series PRX3000 continued on next page

ECG® Relays and Accessories

Series PRX3000 (cont'd)

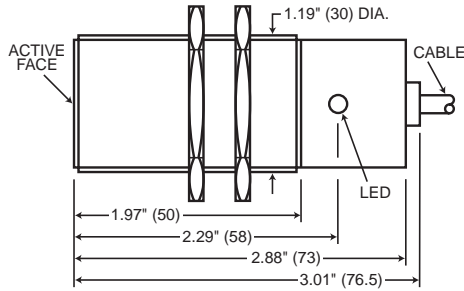

Fig. P60

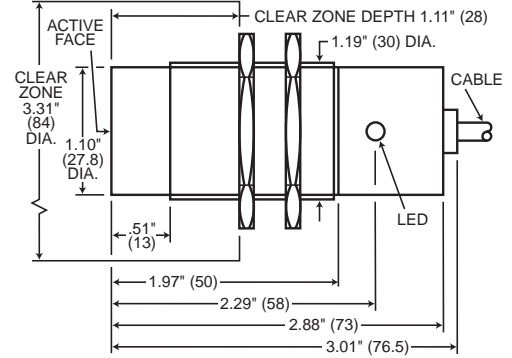

Fig. P61

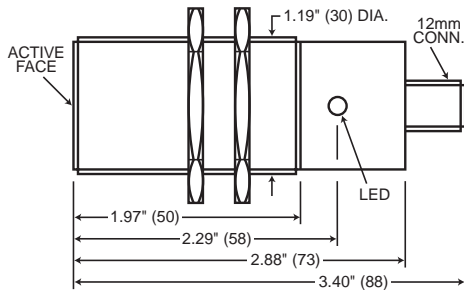

Fig. P62

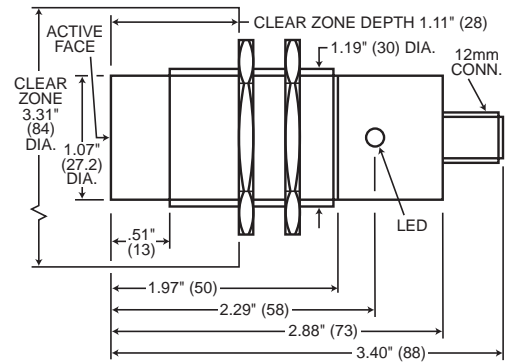

Fig. P63

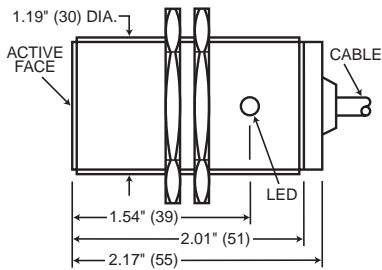

Fig. P64

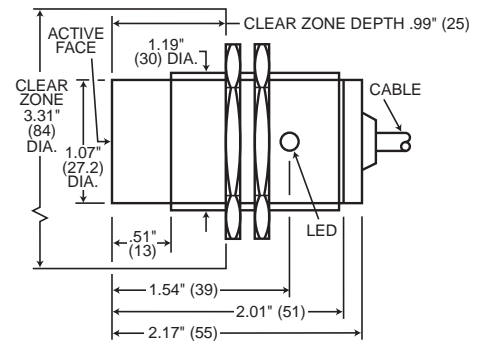

Fig. P65

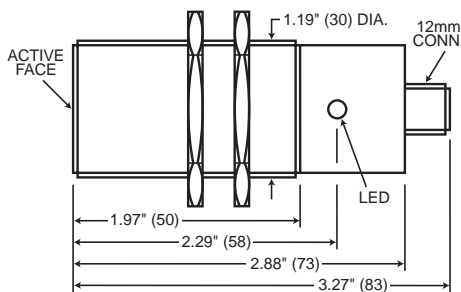

Fig. P66

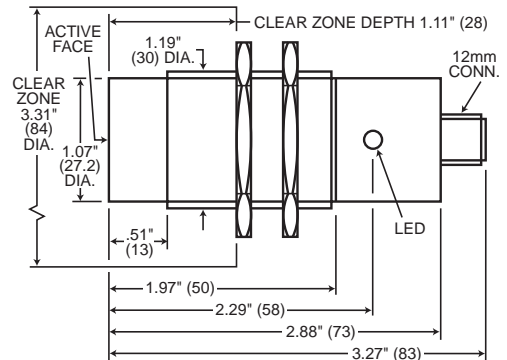

Fig. P67

Inductive Proximity Switch Accessories Series PRX9000

12mm Microconnectors with Integral Molded 5M Cable



ECG Type	Fig. Description	No.
PRX9000	DC, 4-Pin Straight Connector/Cable	PA1
PRX9001	DC, 4-Pin Rt Angle Connector/Cable	PA2
PRX9002	AC, 3-Pin Straight Connector/Cable	PA3
PRX9003	AC, 3-Pin Rt Angle Connector/Cable	PA4

Specifications

Connector Shell Thermoplastic,
Meets UL94 Standards
Contacts Gold Plated
Cable Length/Wire Size 5 M/25 AWG
Voltage Rating 250VAC/DC
Isolation Resistance 1000 MΩ
Operating Temp -40°C to +90°C
Thread Size M12 x 1

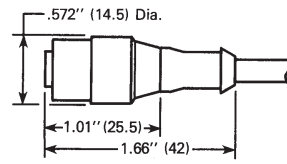

Fig. PA1

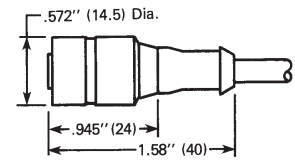

Fig. PA3

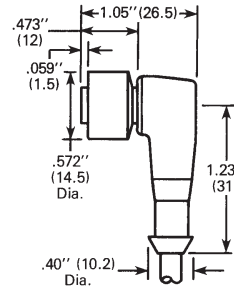

Fig. PA2

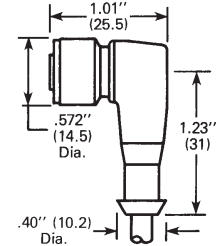
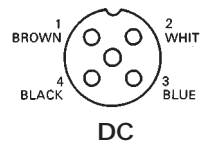
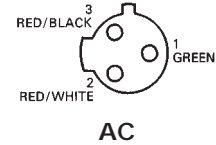

Fig. PA4



DC



AC

Mounting Brackets



ECG Type	Description	Fig. No.
PRX9108	8mm Bracket, Series 800 Switches	PA5
PRX9112	12mm Bracket, Series 1200 Switches	PA5
PRX9118	18mm Bracket, Series 1800 Switches	PA5
PRX9130	30mm Bracket, Series 3000 Switches	PA5

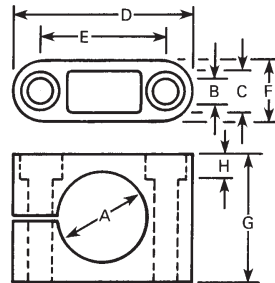
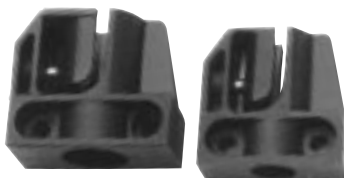

Fig. PA5

ECG Type	A In	B In	C In	D In	E In	F In	G In	H In
PRX9108	.315 (8)	.178 (4.5)	.315 (8)	1.07 (27)	.670 (17)	.473 (12)	.630 (16)	.178 (4.5)
PRX9112	.473 (12)	.178 (4.5)	.315 (8)	1.26 (32)	.867 (22)	.473 (12)	.788 (20)	.178 (4.5)
PRX9118	.709 (18)	.178 (4.5)	.315 (8)	1.42 (36)	1.03 (26)	.473 (12)	.788 (20)	.178 (4.5)
PRX9130	1.19 (30)	.217 (5.5)	.394 (10)	2.17 (55)	1.66 (42)	.709 (18)	1.50 (38)	.217 (5.5)

Microswitch Adapters



ECG Type	Description	Fig. No.
PRX9212	12mm Adapter, Series 1200 Switches	PA6
PRX9218	18mm Adapter, Series 1800 Switches	PA6

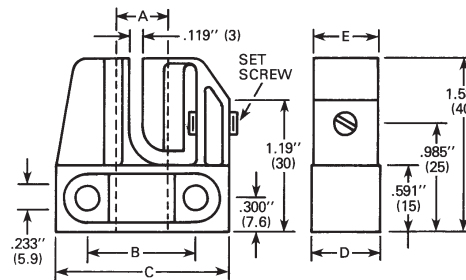

Fig. PA6

ECG Type	A In	8 In	C In	D In	E In
PRX9212	.473 (12)	.985 (25)	1.58 (40)	.630 (16)	.591 (15)
PRX9218	.717 (18.2)	1.19 (30)	1.78 (45)	.867 (22)	.867 (22)

PRX9900 Proximity Switch Tester

- Tests All Types
 - ✓ Inductive
 - ✓ Capacitive
 - ✓ Photoelectric
 - ✓ AC - 2 and 3 Wire
 - Normally Open
 - Normally Closed
 - ✓ DC - 2, 3 and 4 Wire
 - NPN
 - PNP
 - Normally Open
 - Normally Closed
 - Complimentary
 - NAMUR
- No Need To Remove Switch To Test
- Go/No Go LED Indicators
- Quick Connect Terminals
- Battery Operated



Specifications

General

LED Indicators: Hi-bright red LEDs

Terminals: Spring loaded, quick connect

Power: 9 V alkaline or carbon-zinc battery (NEDA 1604)

Battery Life: 15 hours typical with carbon-zinc cells, 30 hours typical with alkaline cells

Protection Rating: NEMA 1, IP 21 (General Purpose)

Dimensions: 120 mm x 65 mm x 40 mm (4.75" x 2.56" x 1.56")

Tests Switch Types

AC Switches: 2 or 3 wire, Normally Open or Closed

DC Switches: 2, 3 or 4 wire, Normally Open or Closed, NPN, PNP, NAMUR